

KEENCUT

EXCALIBUR

1000X
1000XE
5000

® INSTRUCTION MANUAL

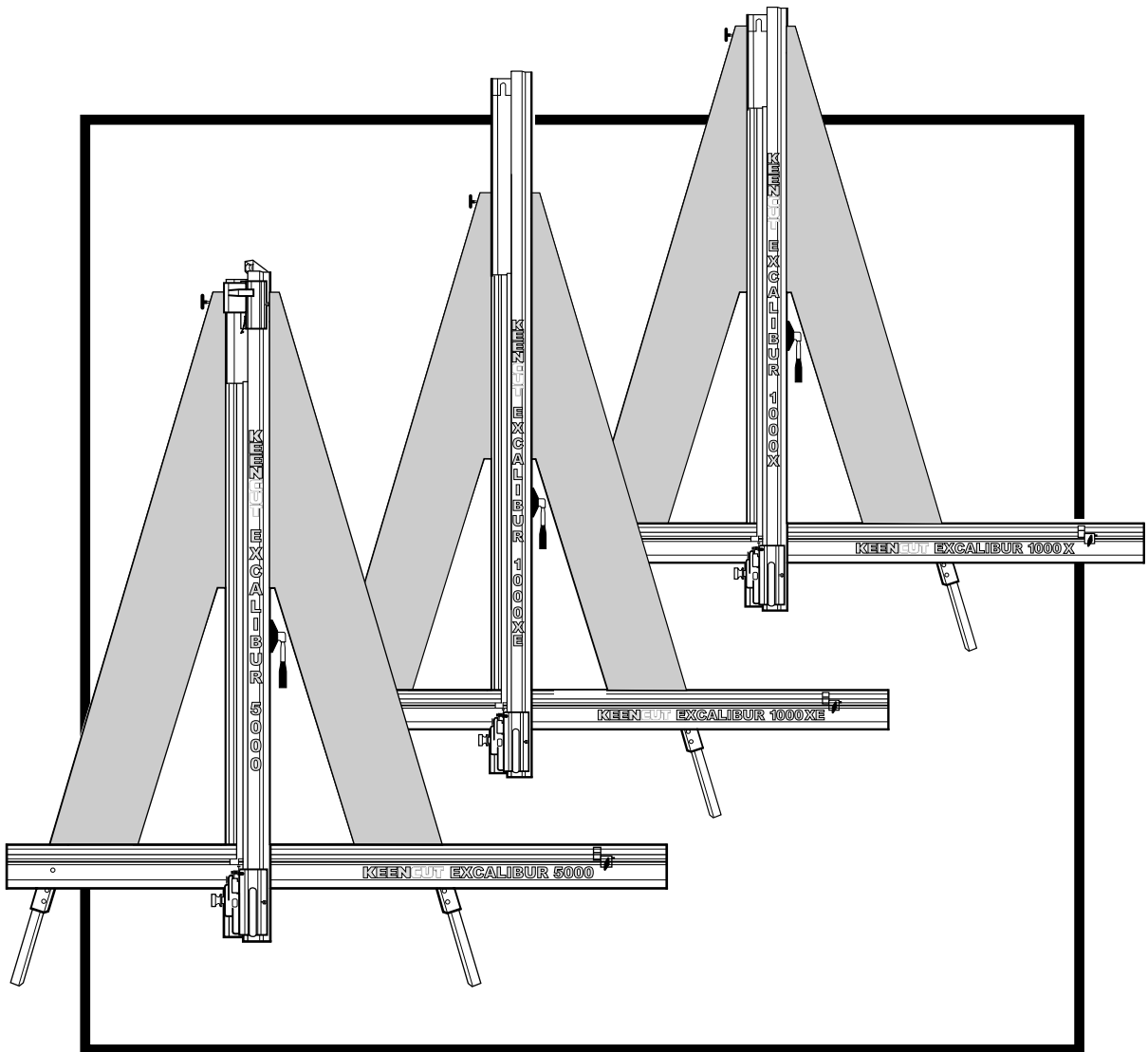

Single language version and parts diagrams can be
down loaded from www.keencut.co.uk

2 Packing list

- 2.1 Unpacking your machine

3 Assembly

- 3.1 Adjusting the Legs
- 3.2 Preparing to fit the Squaring arm
- 3.3 Fitting the Squaring arm
- 3.4 Fitting the Wall mounting bracket
- 3.5 Fitting the Free standing kit
- 3.6 Fitting the Backing panels

4 Squaring

- 4.1 Checking your machine for squareness
- 4.2 Adjusting the squareness

5 Calibration

- 5.1 Calibrating the vertical square
- 5.2 Calibrating the Squaring arm scale
- 5.3 Fitting the Sight-line strip

6 Operation

- 6.1 Using the Clamp
- 6.2 The Multi-tool cutter and the Counterbalance – **5000**
 - 6.2.1 The Cutting blade
 - 6.2.2 The Scoring blade
 - 6.2.3 The Glass cutter
- 6.3 The Twin wheel cutter – **5000**

7 Maintenance

- 7.1 General maintenance
-

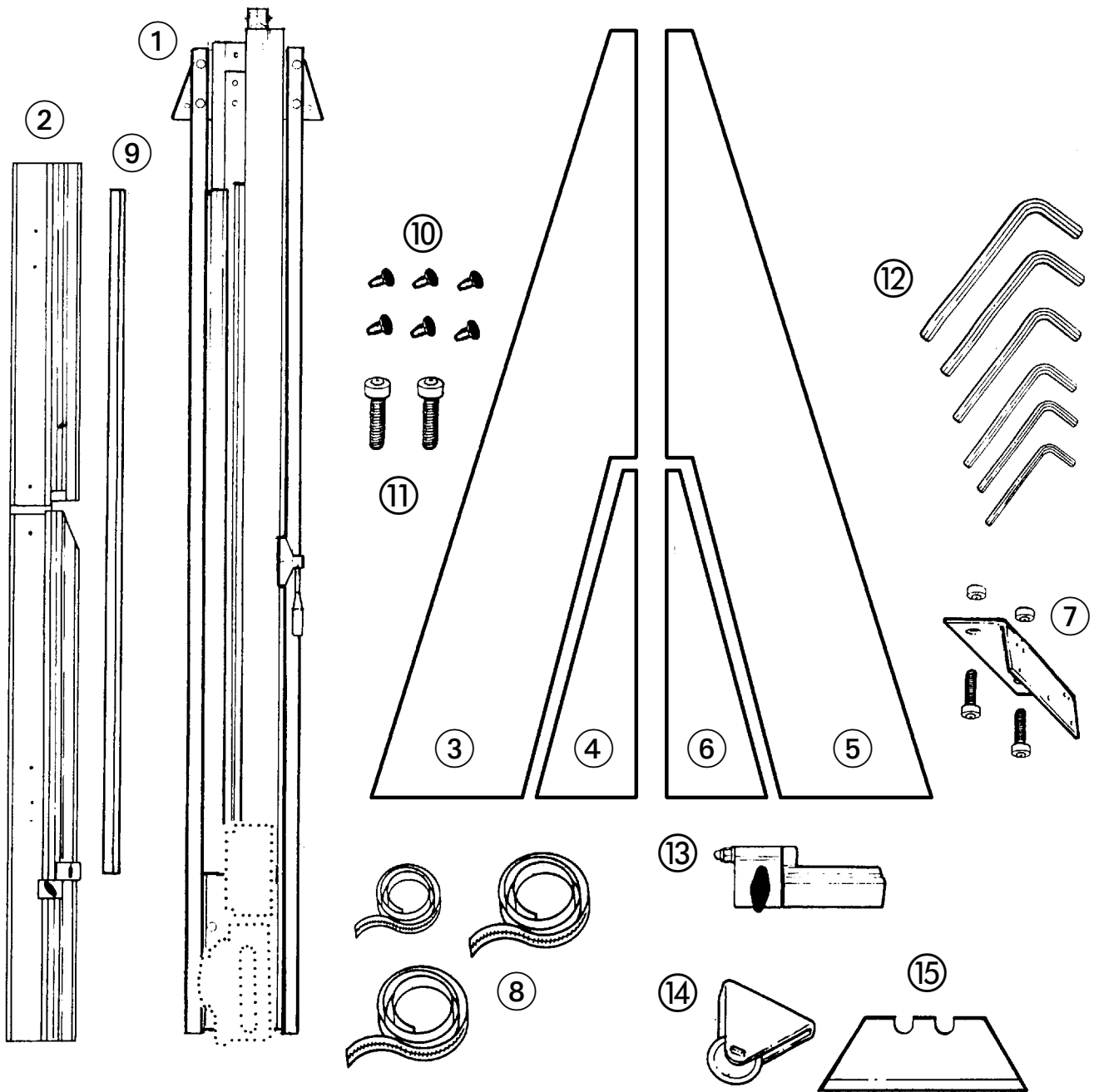

NOTE: When lifting the main body from the box, DO NOT lift using the black handles on the cutters.

1. Main body *
2. Squaring arm
3. Left large back panel
4. Left small back panel
5. Right large back panel
6. Right small back panel
7. Wall mounting bracket
8. Measuring rules
9. Spare sight-line strip
10. Plastic rivets

11. M8 screws
12. Hexagon wrenches
2.0, 2.5, 3.0, 4.0, 5.0, 6.0mm
13. Left hand production stop
14. Spare glass cutting wheel
15. Spare blades

* NOTE: Cutting Head arrangements differ according to machine type

Adjusting the Legs

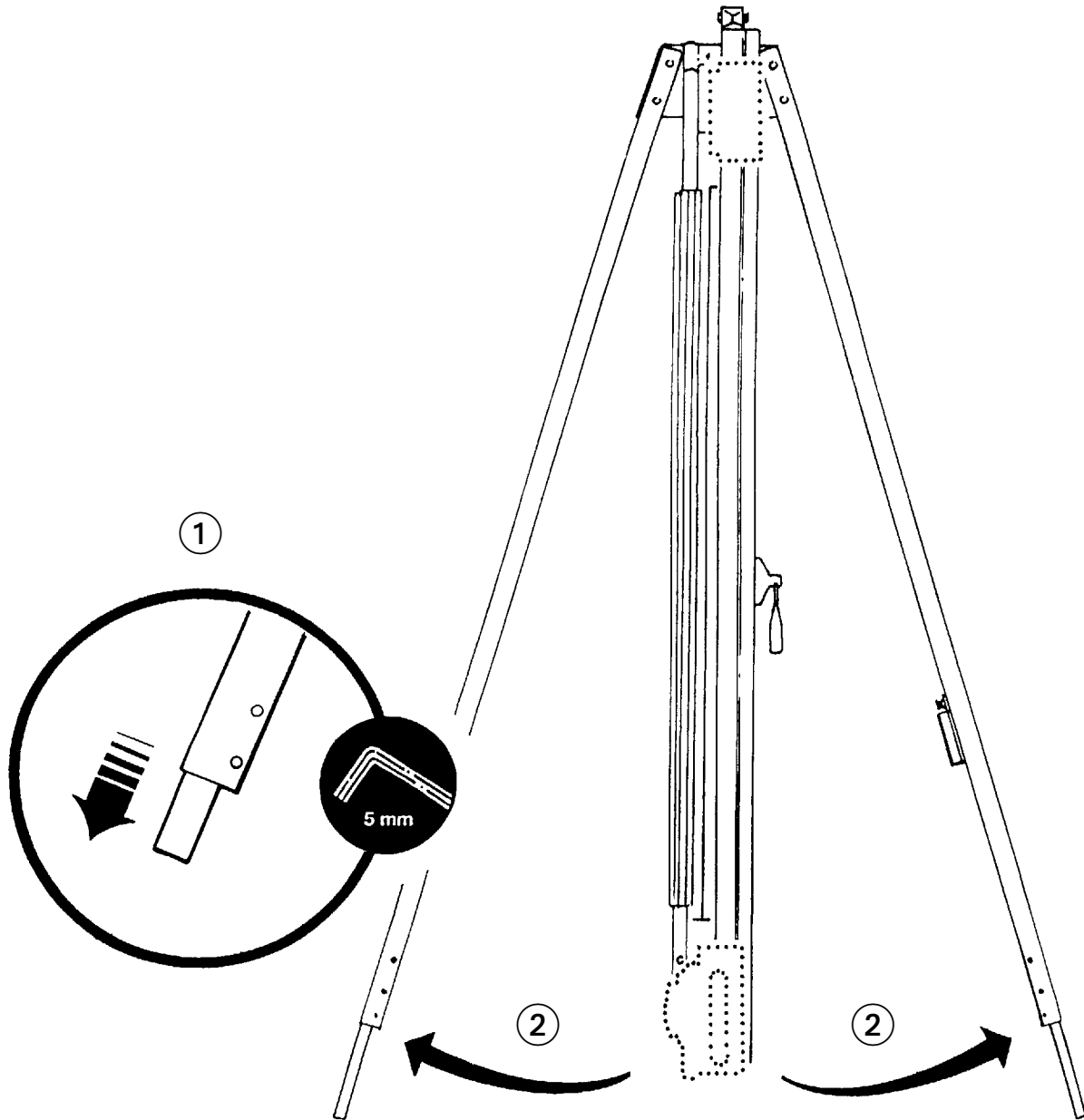

The first stages of assembly are carried out with the machine laying on the floor.

NOTE: When lifting the main body from the box do not lift using the black handles on the cutters.

Remove the **Main body** from the box and lay it on the floor, remove the packaging from the bottom end.

1. Slacken the bottom two screws on each leg using the **5mm Hexagon wrench** and extend the telescopic parts to the desired length. (These can be re-adjusted later before fixing the machine to the wall). Tighten screws firmly to clamp in position.
2. Swing both legs outwards as far as they will go.

Preparing to fit the Squaring Arm

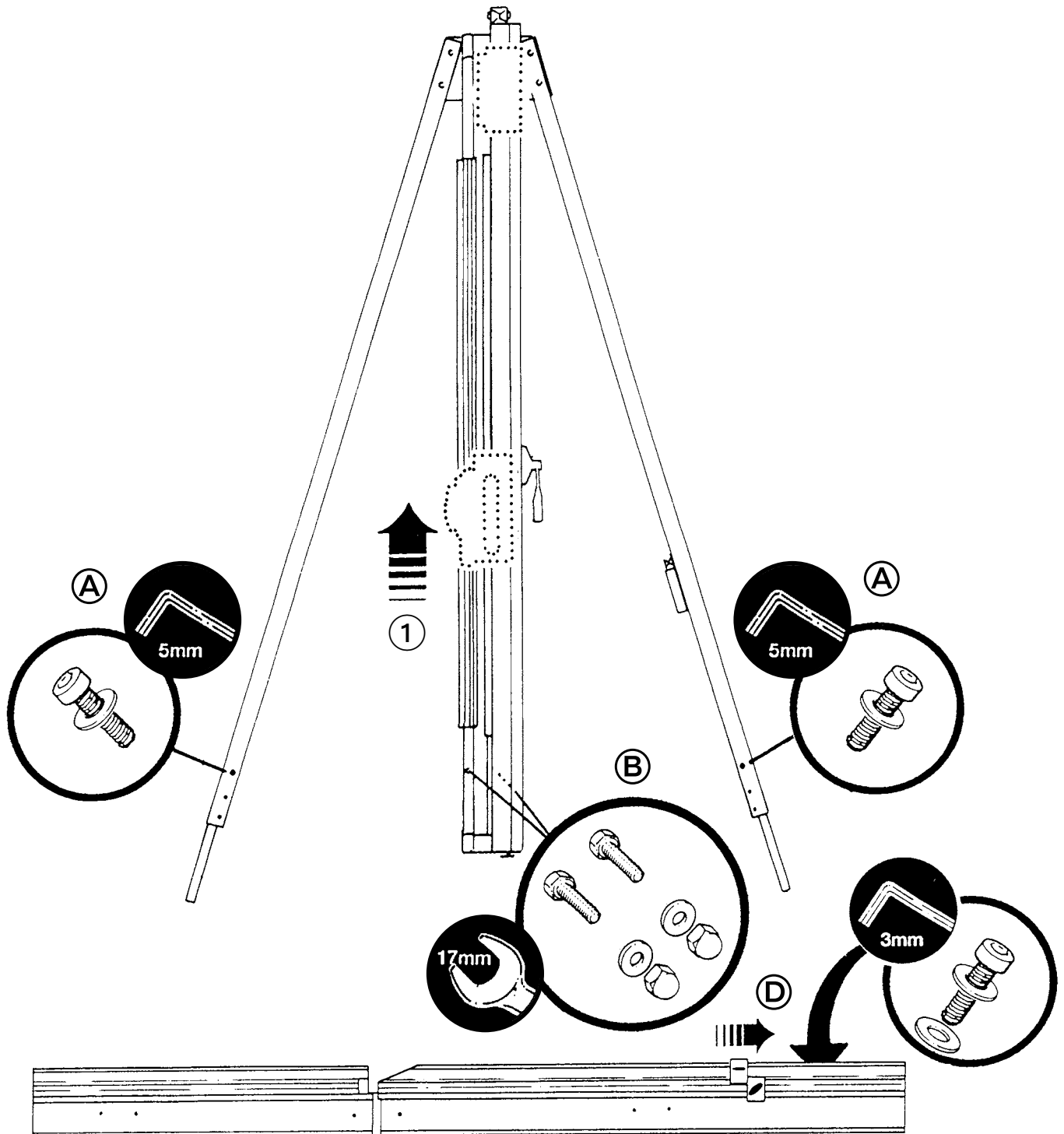

1. Move the lower cutting head to the middle of the **Main body**.
2. Remove the following:
 - A. One screw from each leg, using **5mm Hexagon wrench**.
 - B. Two sets of Hexagon headed bolts, washers and nuts from the **Main body** using 17mm Spanners.
 - C. Remove small **Screw** and two **Washers** from the back of the squaring arm using 3mm hexagon wrench.
 - D. Slide off **Right hand production stop** (this will need to be replaced further on).

Fitting the Squaring Arm

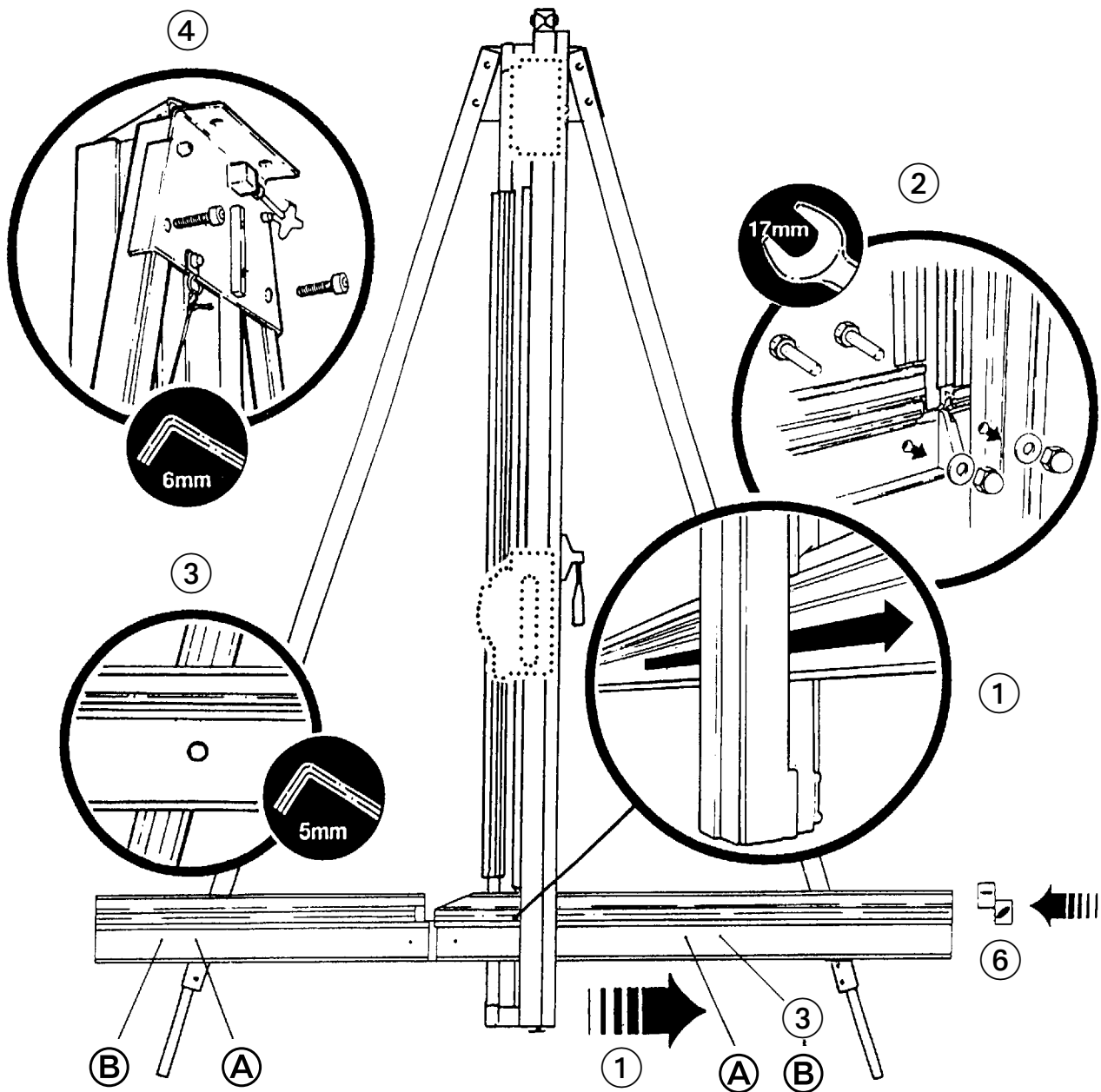

1. Slide the **Squaring arm** in from the left hand side through the gap in the **Main body** and align the corresponding screw holes.
2. Fit the two Hexagon bolts from the back of the **Main body**, fit the washers and nuts **finger** tight only.
3. Fit the screws through the **Squaring arm** * into the leg using the **5mm Hexagon wrench**, do not tighten fully.
4. Fit the two **M8 Screws** to secure the legs at the top of the **Main body** using the **6mm Hexagon key**, tighten both screws fully. Tighten the other two adjacent M8 screws.
5. Now tighten fully the screws and nuts as in 2 & 3 above.
6. Replace **Right hand production stop, Screw** and two **Washers** using 3mm hexagon wrench.

* Use holes **A** on 122cm (48") and **B** on 160cm (63") machine.

Fitting the Wall Mounting Bracket

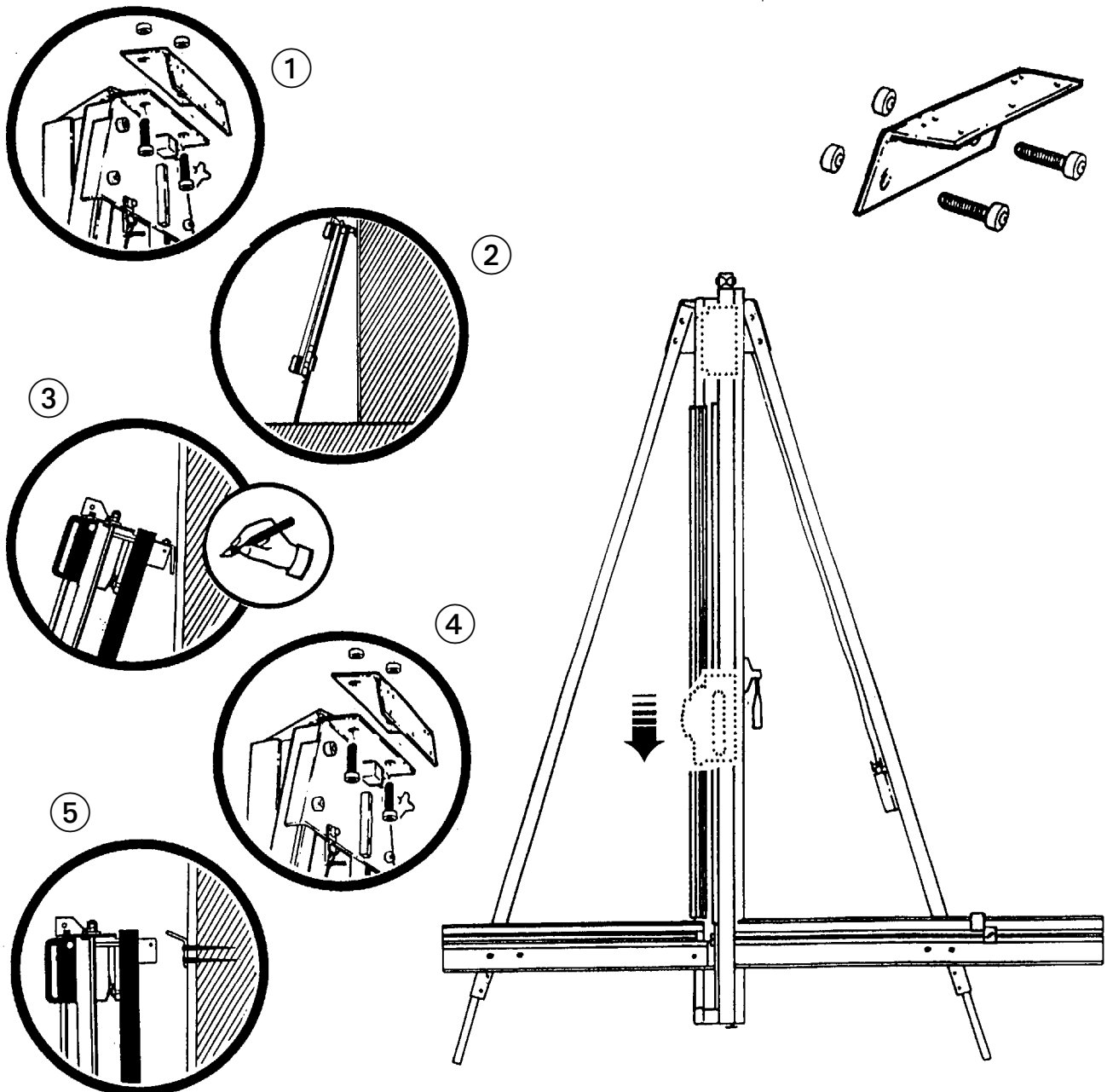

NOTE A: If you are going to fit the *Free standing kit* (optional) turn to next page.

NOTE B: Ensure the wall is stable and use the appropriate fixings.

Move the *lower cutting head* to the bottom of the *Main assembly*.

1. Fit the **Wall mounting bracket** to the top of the **Main body**, fasten the screws finger tight only.
2. Lean the machine against the wall in the desired place.
3. The **Wall mounting bracket** should lay flush against the wall. Mark the position of the wall fixings with a short pencil.
4. Move the machine away and remove the **Wall mounting bracket**.
5. Attach the bracket to the wall in the marked position with appropriate fixings then reposition and fasten the machine to the bracket.

Fitting the Free Standing Kit (optional)

NOTE: The *Free standing kit* is an **optional** extra and does not come packed with the main machine.

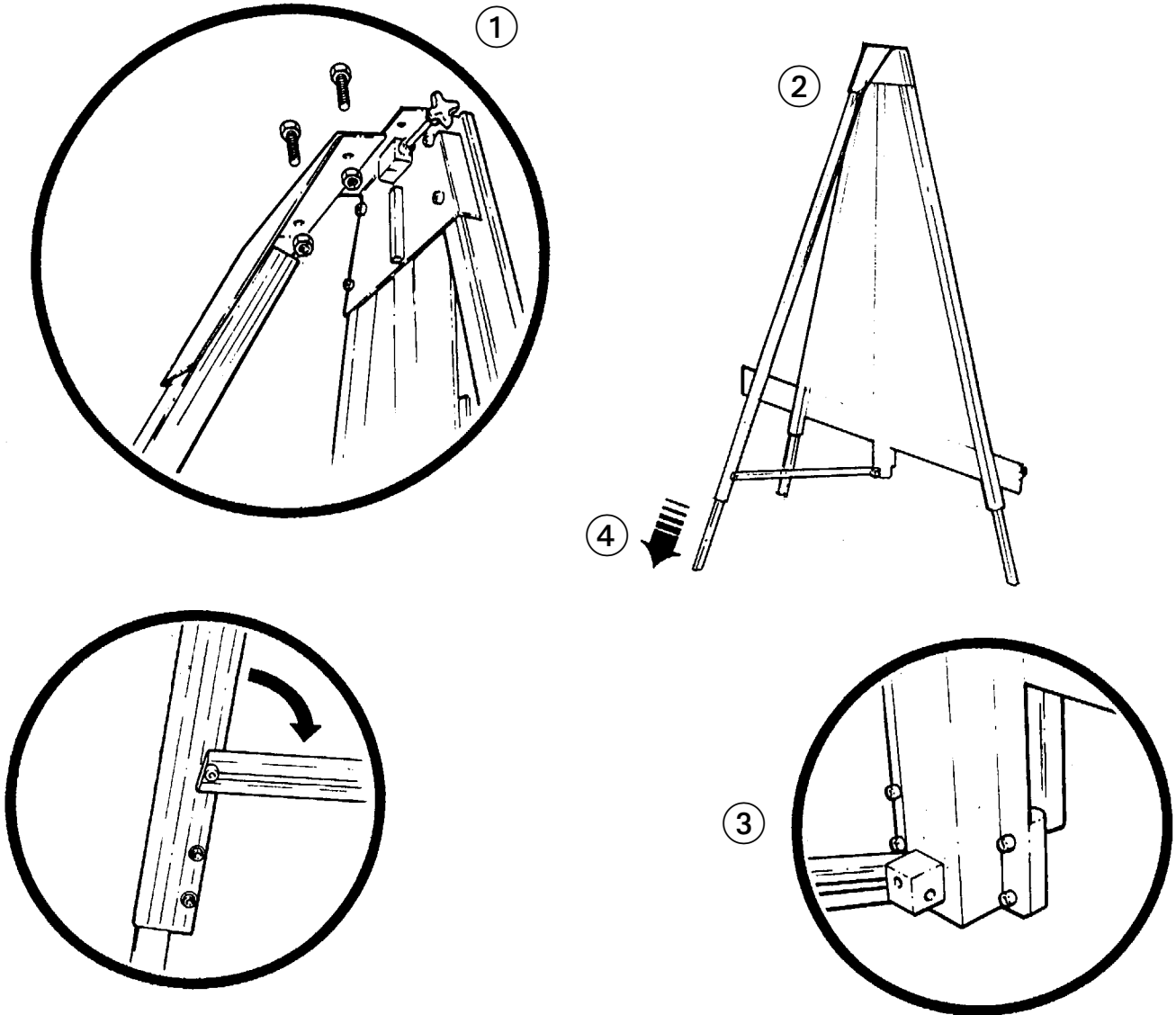

1. Attach the bracket to the top of the machine using the nuts and screws (provided with the main machine).

Extend the telescopic leg to the same length as the front legs less 12cm (5")

Assistance will be needed for the following stages

2. Get help to stand the machine up and hold it while the **free standing leg** is fixed to the bracket using the 6mm hexagon wrench..
3. Swing down the stay and attach the fixing block to the back of the **Main body**, tighten all three screws on the stay (using 5mm & 6mm hexagon wrenches).
4. Extend the telescopic leg so the machine stands evenly as shown.

Fitting the Backing Panels

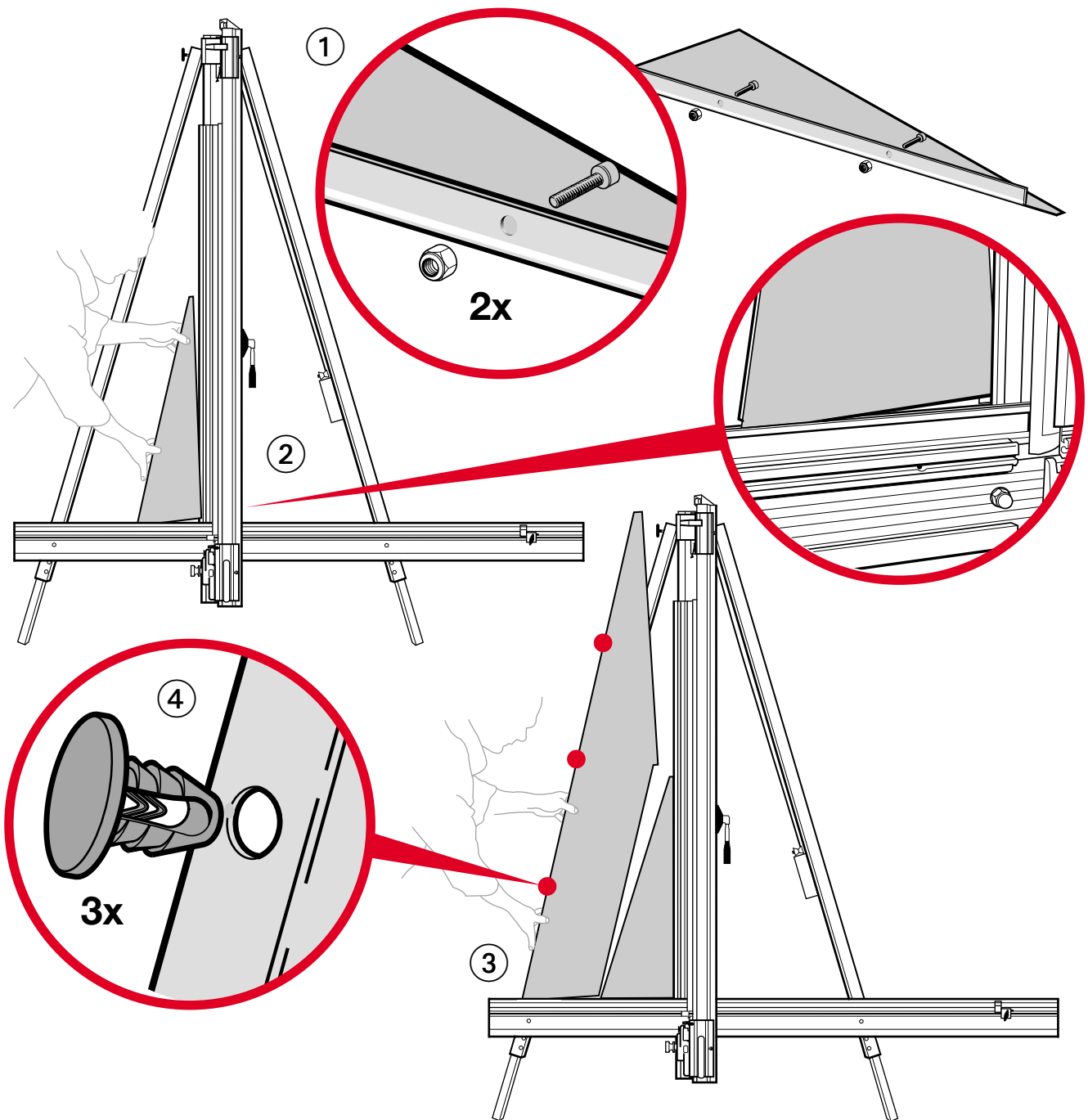

1. Remove the screws and nuts from the edge of the **Left small back panel**.
2. Fit panel into the groove on the top edge of the **Squaring arm**, slide the panel to the right and locate the vertical edge into the groove in the **Main body**. be careful not to damage the edge of the panel.
3. Fit the **Left large back panel** into the groove on the top edge of the **Squaring arm**, slide it to the right to meet the small panel.
4. Knock in the three **Plastic rivets** to secure the panel to the leg and fasten the two panels together with the screws and nuts provided.

Fitting the Backing Panels

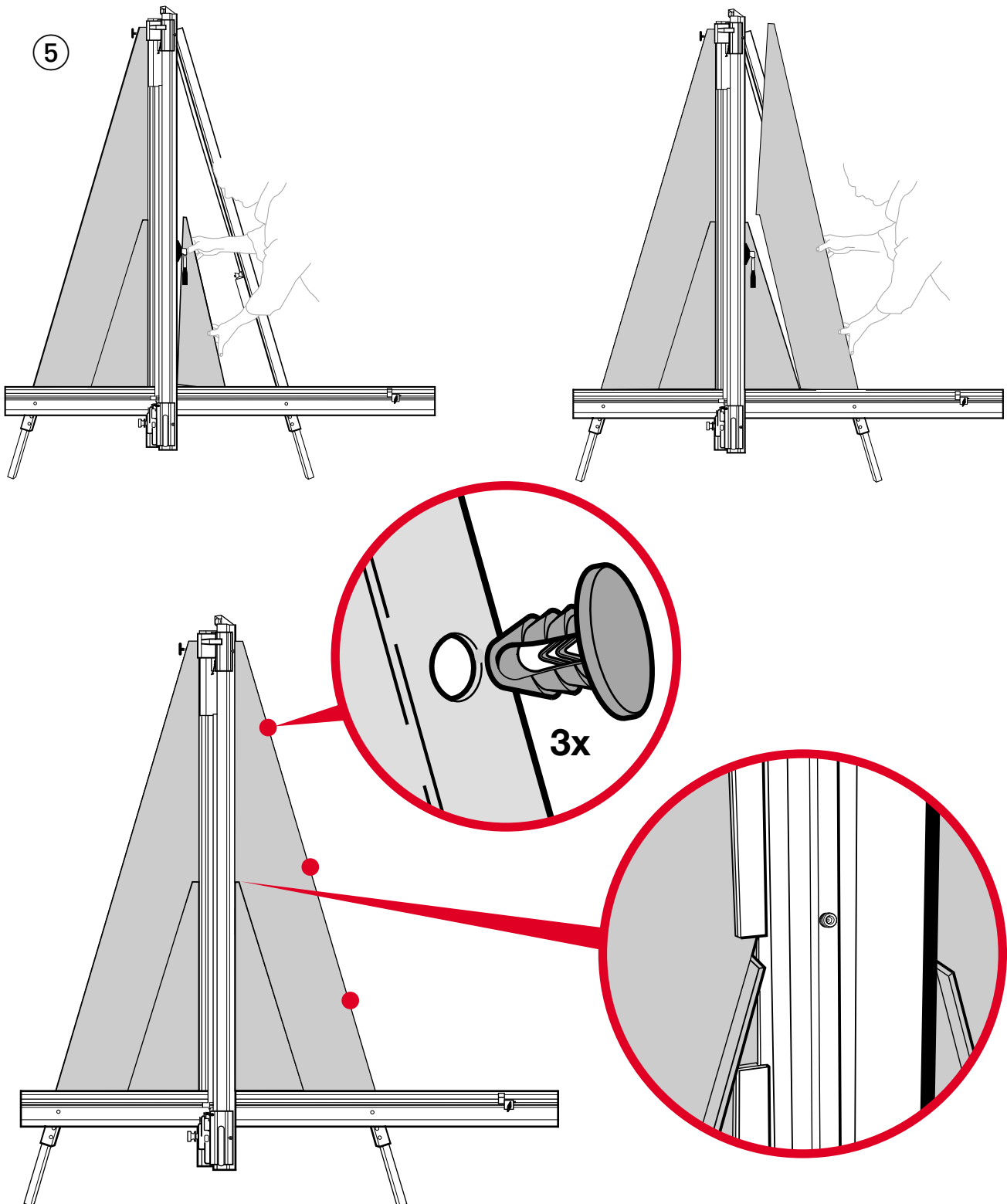

5. Repeat for the **Right hand panels**. In place of a vertical groove in the main body the panels have metal strips fixed to the back which grip the edge of the main body as shown.

Checking your machine for Squareness

For your machine to produce accurate square cuts the Main Body needs to be set so that it is 90° to the Squaring Arm, for the following procedure you will need a piece of card or matboard at least 60cm x 100cm (2' x 3') the larger the board the more accurate you can set the machine.

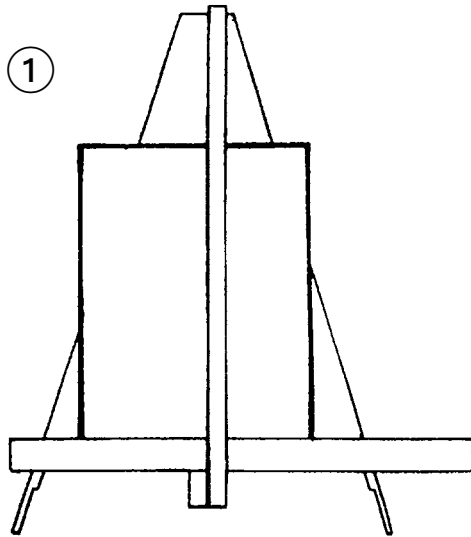

Place the board on the machine vertically as shown and apply the clamp ensuring the bottom edge is in firm contact with the Squaring Arm.

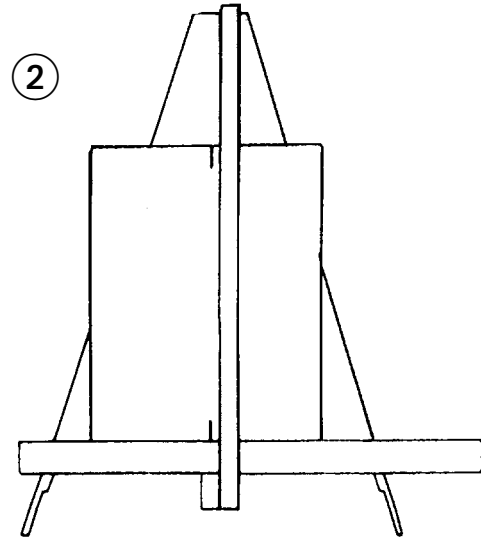

Select the cutting blade on the lower cutting head (see section 6). Cut into the top of the board to produce a cut approximately 3cm (1") long. Disengage the cutter using the cutter release lever. Lower the cutter and make a similar cut at the bottom of the board.

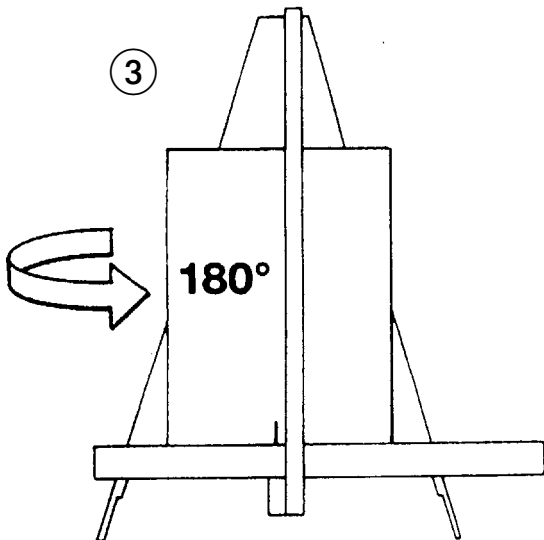

Unclamp and turn the board around (like the page in a book) and place it back in the machine so the same edge is still on the squaring arm but do not clamp it. Align and engage the blade so it enters the previous made cut at the bottom edge of the board. Now apply the clamp.

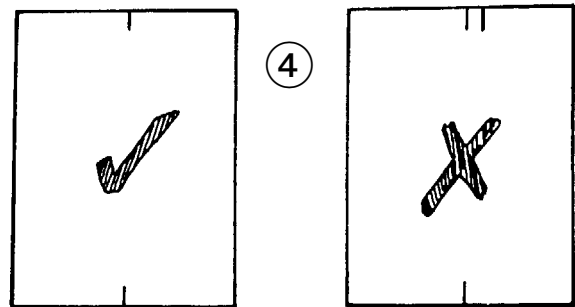

Raise the cutter to the top of the board, if the machine is square the blade should enter the same cut as made previously. If not refer to the following page to make the necessary adjustment.

Adjusting the Squareness

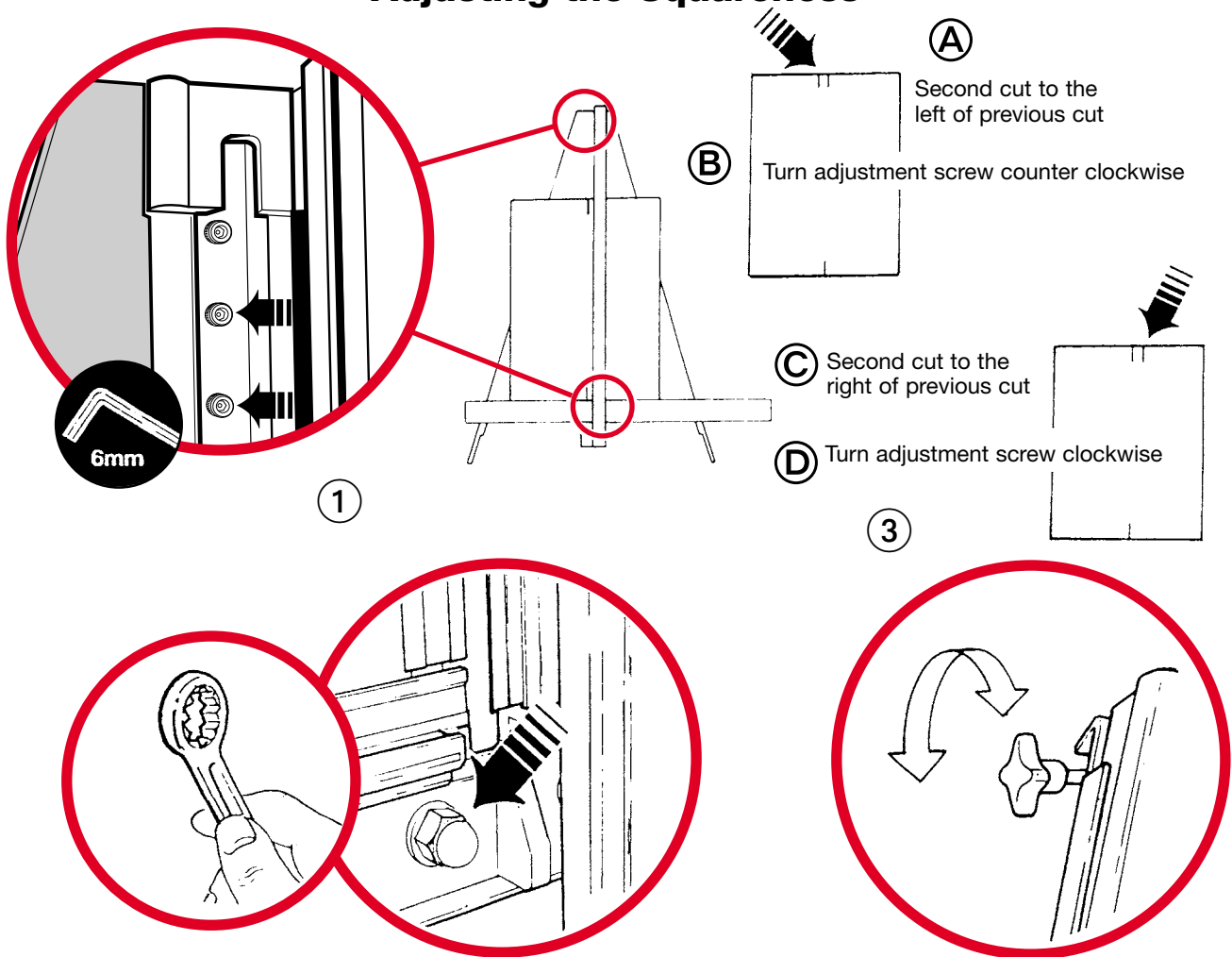

NOTE: Before making any adjustments carry out the squareness check as described on the previous page.

It is assumed that the board used for the test is still clamped in the machine. From the test results determine if the last cut made in the top of the board is to the left or right of the previous cut, as shown above:

1. Slacken the bottom two of the three screws at the top of the Main Body using the 6mm hexagon wrench, then slacken the left hand nut at the bottom using a 17mm ring spanner, make sure the right hand nut is tight.
2. Release the clamp and position the board such that the blade is held in the cut on the bottom edge of the board.
3. Turn the adjustment knob at the top of the Main Body in the direction shown in the drawing such that the blade when moved to the top of the board cuts between the two existing cuts.
4. Repeat the squareness check.
5. Tighten the screws and nut (as in 1.).

Calibrating the Vertical scale

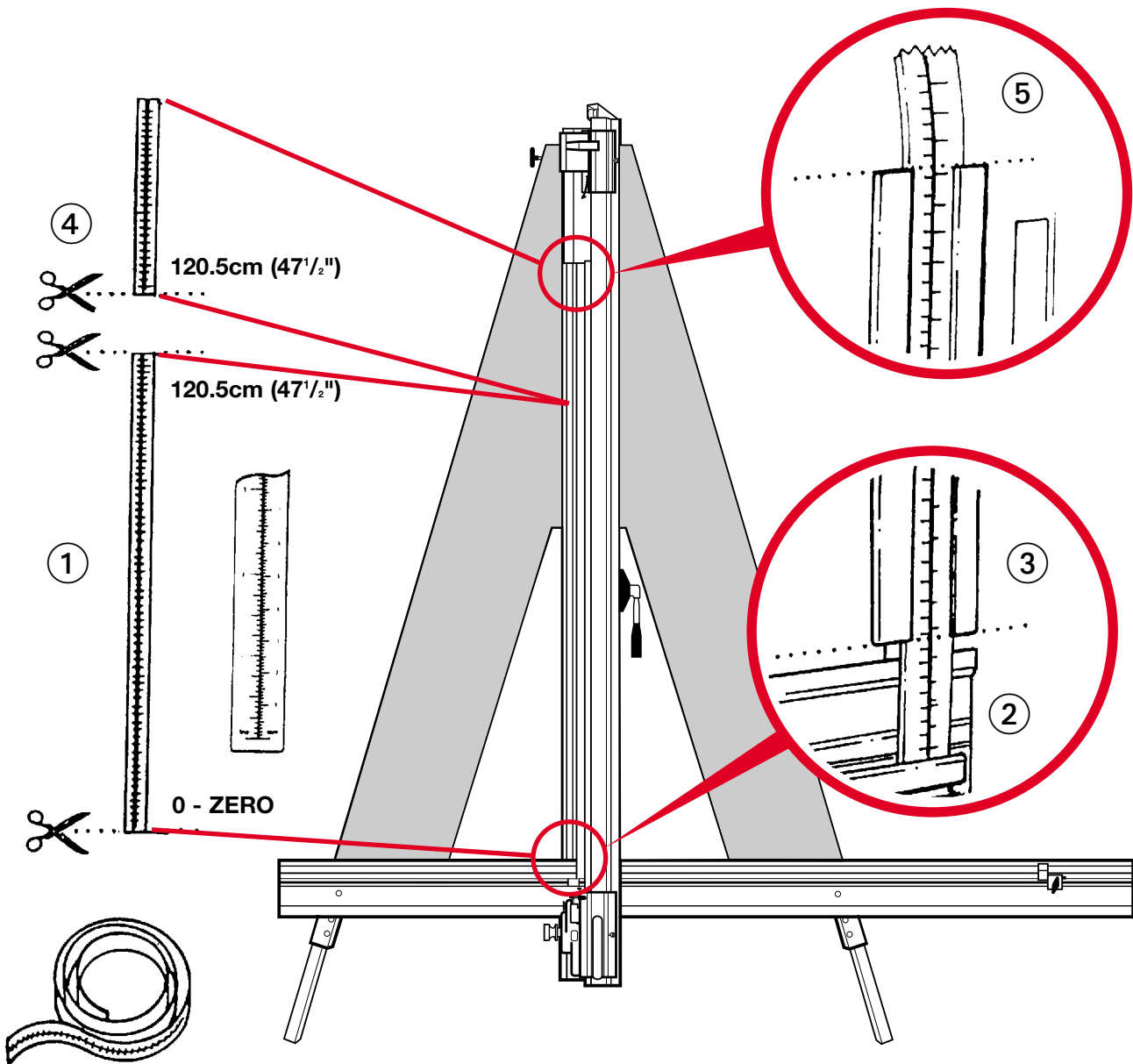

NOTE: The *Vertical rules* can be identified from the *Squaring arm rule* by the orientation of the printed measurements – see diagram.

1. Trim the bottom scale at zero and 120.5cm (47 $\frac{1}{2}$ ") with scissors.
2. Remove the paper backing tape and carefully place the **Rule** adjacent to its groove in the **Main body** and with the zero end resting inside the material channel of the **Squaring arm**. When aligned stick the **Rule** in its groove.
3. Again trim the **Rule** at the bottom end as shown.
4. Trim the **Rule extension** to 120.5cm (47 $\frac{1}{2}$ ") and stick it in place above the previous **Rule**.
5. Trim the top of the **Rule extension** as shown.

Calibrating the Squaring arm scales

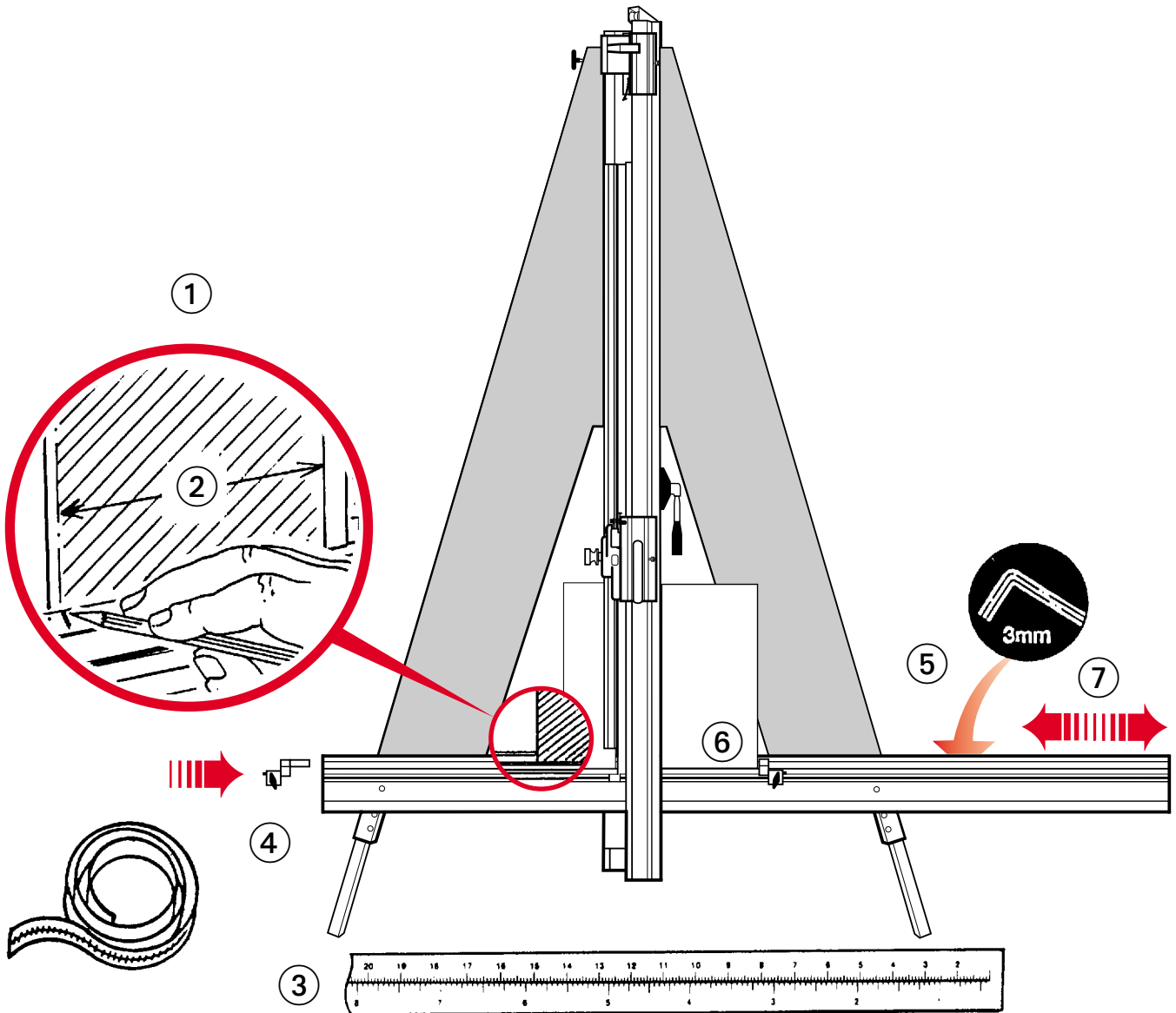

NOTE: The *Squaring arm rule* can be identified from the *Vertical rules* by the orientation of the printed measurements – see diagram.

LEFT HAND SCALE

1. Place a piece of card in the machine and apply the clamp. Mark the top edge of the **Squaring arm** with a pencil (*this can be removed with an eraser later*) adjacent to the left hand edge of the board.
2. Cut the board and measure the width of the cut.
3. Peel the backing tape from the **Rule** and place it in its groove so the pencil mark lines up with the corresponding dimension on the rule (as measured).
Trim the right hand end accordingly.
4. Fit the Left hand Production stop.

RIGHT HAND SCALE

5. The top edge of the **Squaring arm** slides left to right to enable calibration. Use the 3mm Hexagon wrench to loosen the **Screw** in the back of the **Squaring arm** if adjustment is necessary.
6. Clamp another piece of card in the machine and move the Production stop to it.
7. Cut the card and measure, adjust the sliding scale so that the Production stop indicates the measured size.

Fitting the Sight-line strip

NOTE: A spare **Sight-line strip** is included with the machine, replacement strips are available from Keencut distributors.

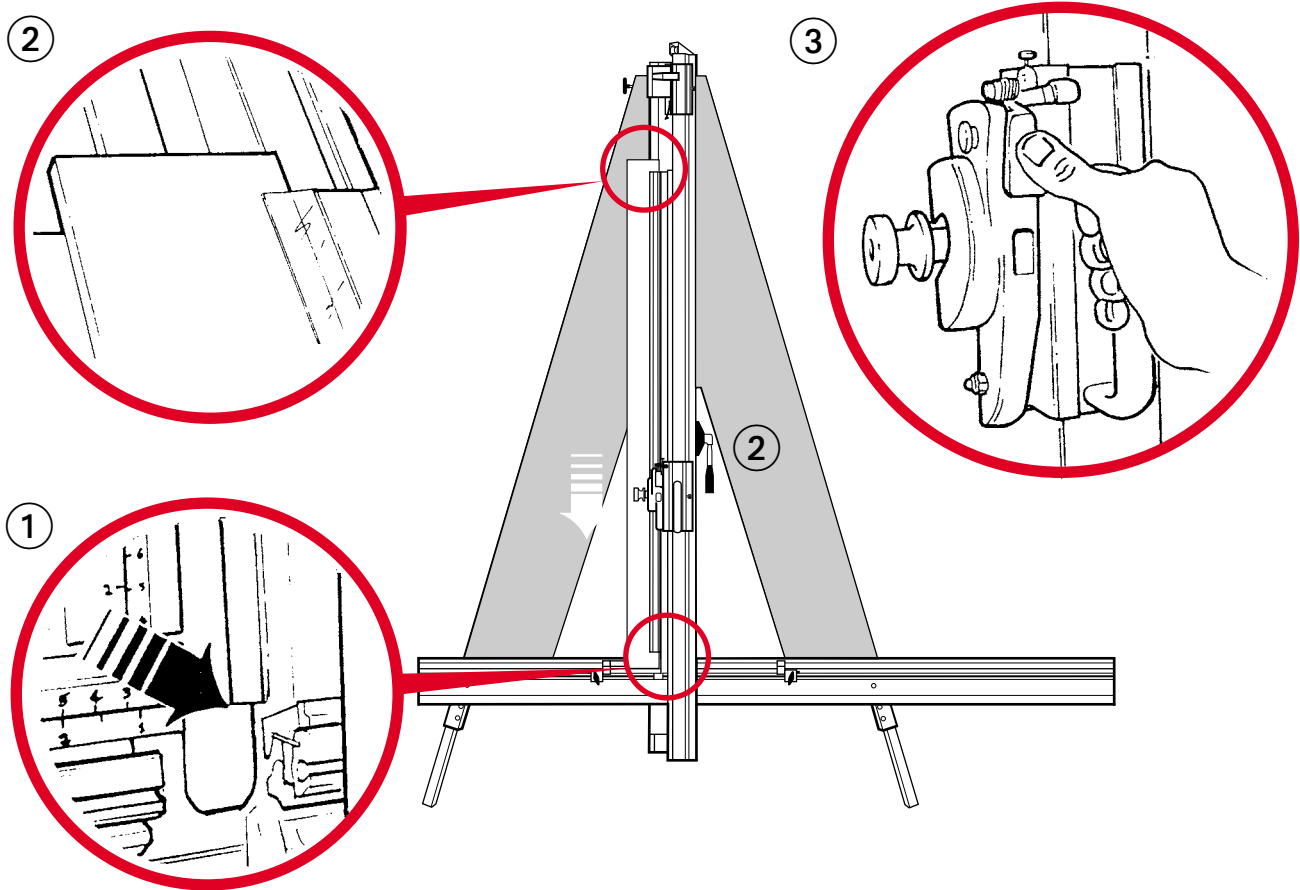

The **Sight-line strip** is fixed to the clamp and then trimmed by the cutting blade to give an accurate guide when cutting to trim lines, the edge of an image or pencil marks. The clamp simply operates by moving the handle in and out, (more information on operating the clamp is given later).

1. Ensure the edge of the clamp is clean from dust and wipe with cleaning spirit applied to a cloth. Remove the backing paper from the **Sight-line strip**, starting at the bottom of the clamp stick it firmly in its groove, working your way to the top of the clamp. There may be a small amount of the strip overhanging at the top.
2. Clamp a piece of scrap card or foam centred board (3-6mm, {1/8"-1/4"} thick) under the **Sight-line strip** but **not** under the clamp itself. Depress the clamp handle such that the **Sight-line strip** is pressed flat across the surface of the board.

NOTE: If the board is not available to go the full length of the clamp use a smaller piece and trim the strip in stages.

3. Hold down the top left corner of the strip with your finger (be careful) and trim down the **Sight-line strip** in two or three light strokes, holding the tip of the blade on by finger pressure. (ie. Disengage the ratchet as on page 6.22.)
4. Trim the top edge level with the top of the clamp.

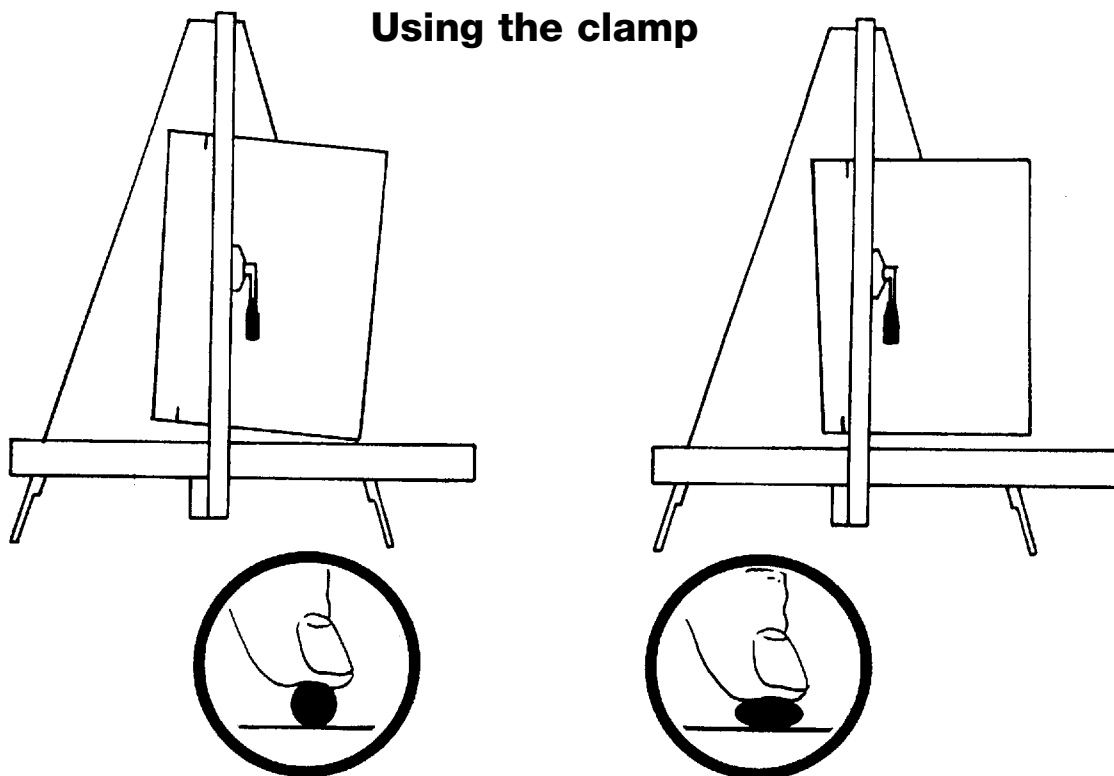

The Clamping system of the Excalibur has been carefully designed to give a controlled clamping force easily set by the operator to suit the task in hand. The clamp has an integral friction brake that regulates clamping force on the material in relation to the amount of pressure applied to the operating lever. So you can clamp delicate materials very gently or thick PVC Foam Boards rigidly to prevent any movement. By following the guidelines below it will help you to get the most from the machine:

USE	CLAMPING INSTRUCTIONS
Cutting Glass	Use very light or no pressure (see 'Using the glass cutter'), the silicon rubber grip strip under the clamping area will grip glass with the minimum of clamp force.
Soft materials such as Foamcore boards, Lightweight card, etc.	Use light to medium pressure, as the underside of the clamp grips an area nearly 4cm (1½") wide with a non-marking sponge rubber reasonable force can be applied. However, for delicate materials or artworks try a sample in the machine first with the good surface facing towards you.
Harder materials such as PVC foam board, MDF or Matboard	Use medium to heavy pressure.
Cropping to trim lines, pencil marks, etc. (See drawing)	Place material in approximate position under clamp, apply light clamp pressure to allow the material to be repositioned when pushed but held stationary when left. Align the trim marks with the edge of the Sight-line strip, press clamp lever to increase clamping pressure to suit the material.

The Multi-tool cutter head & the counterbalance – 5000

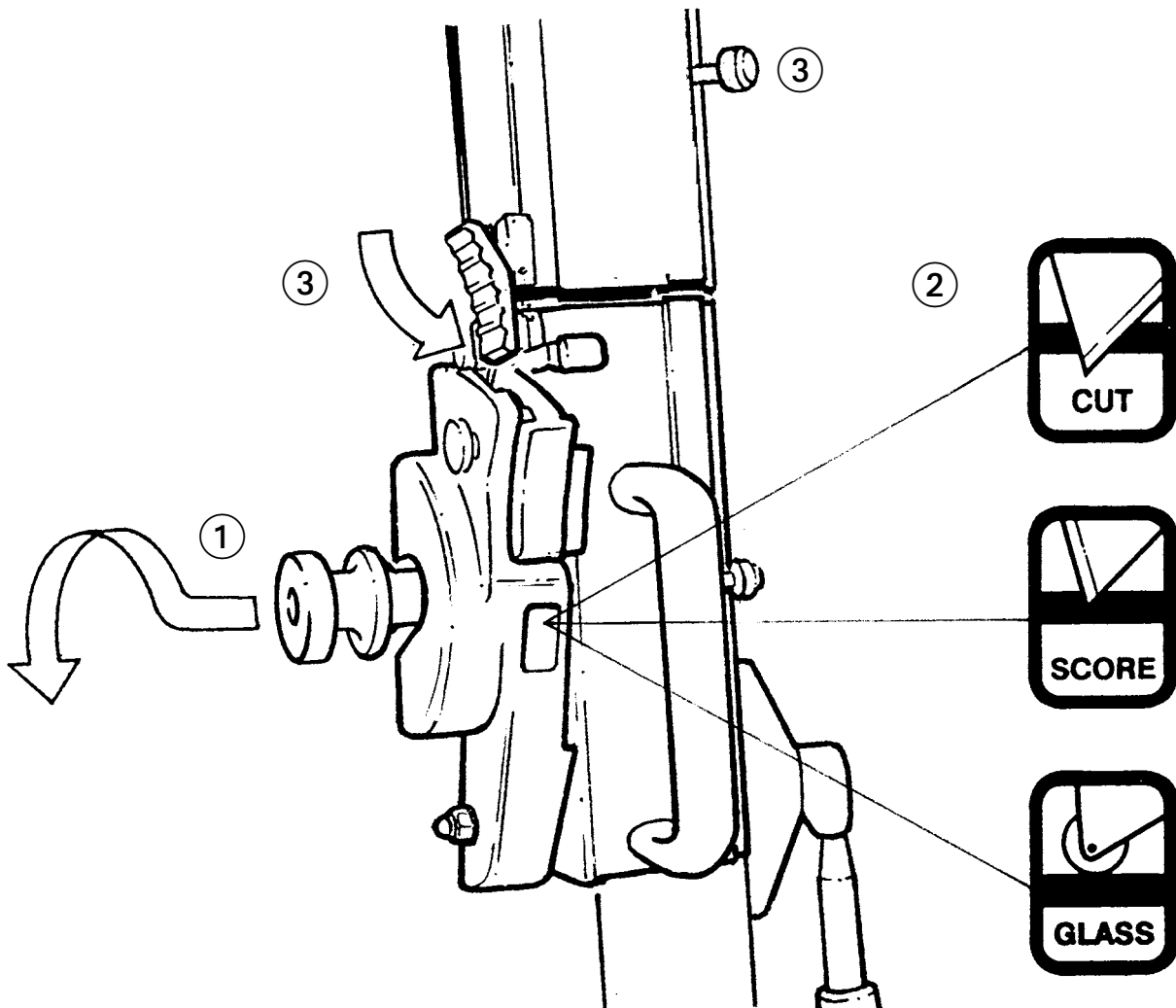

The Excalibur 5000 is fitted with two sliding carriages running on a vertical slideway, each carriage being fitted with a cutting head. The top carriage is fitted with a twin wheel cutter for use with rigid particle boards such as MDF, hardboards and some mount-boards, refer to 'Using the twin wheel cutter' for more details. The lower or Multi-tool cutter head has a rotating turret arrangement where any one of three cutting tools can be selected:

The Cutting Blade

The Scoring Blade

The Glass Cutter

1. To select a different cutter pull the Turret handle out to the left about 6mm ($\frac{1}{4}$ ") and rotate one third of a turn in either direction, the turret will click into the correct position for the next cutter as you continue to rotate the handle.
2. The indicator label seen in the cutter guard window shows which cutter is active.
3. The counter-balance can be attached to either cutting head for easy, fatigue free working. It is normally attached to the twin wheel cutter but to attach it to the Multi-cutter head, lock the twin wheel carriage in place using the white plastic thumb screw. Raise the multi-cutter to engage the counter-balance rocker, press the lower edge of the rocker to connect it to the carriage.

Using the Cutting blade

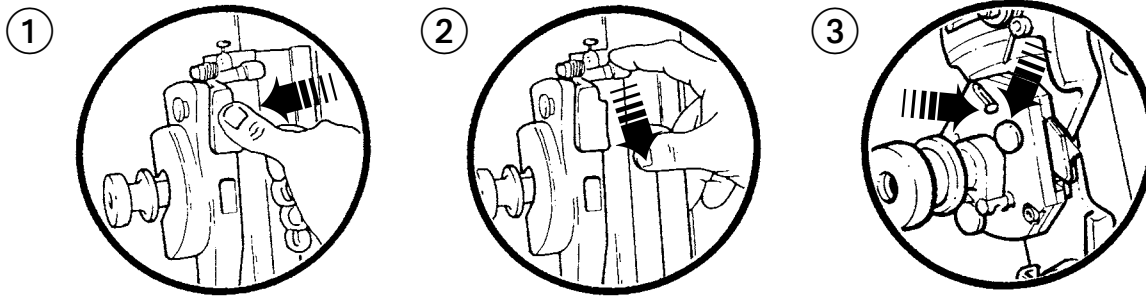

Changing the Cutting blade

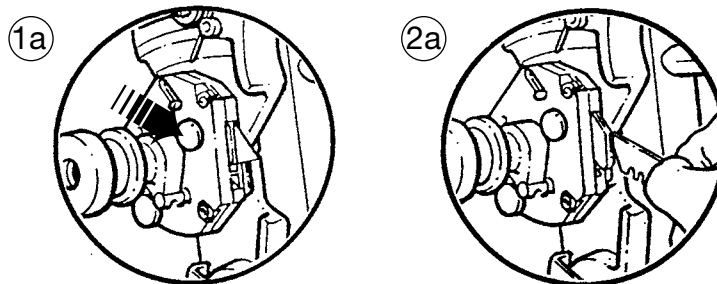

Basic Cutting Technique Select the Cutting Blade position on the turret and clamp the material in the machine.

Move the cutting head beyond the top of the material to be cut.

1. Press to engage the cutter.
Draw the cutter down to the bottom of the machine where it will disengage automatically.
2. Should you engage the cutter by mistake or for any reason want to disengage the cutter without moving it to the bottom of the machine pull down the cutter release lever.

Using the blade support plates The two support plates either side of the blade are designed to give maximum rigidity of the blade when cutting hard or dense materials.

To adjust the support plates swing down the cutter guard by undoing the guard locking knob.

3. Turn the turret 1/2 turn until blade is pointing towards you, unlock the blade clamping screw, the support plates can be adjusted by sliding the black pin in the slot. Move the plates to suit the material.

For cutting most materials the support plates can be set about 12mm (1/2") from the blade tip.

Ratchet Latch

5. A unique feature of the Excalibur is the 'Ratchet Latch', this enables thick dense materials (such as PVC foam board) to be cut easily in stages. Count the number of 'clicks' to position the blade just below the surface of the material to make your first cut then add an extra 'click' for the second and subsequent cuts.

6. Pull down the Latch Lever to disengage the ratchet if required.

As a rough guide when cutting PVC foam boards:-

THICKNESS	TAKE
3mm (1/8")	Initial surface cut + 1 additional cut
5mm (1/4")	Initial surface cut + 1 or 2 additional cuts
10mm (3/8")	Initial surface cut + 3 or 4 additional cuts

The blades are 'Medium Duty Utility Blades' as shown.

Changing the cutting blade

- 1a. Unlock and swing down the cutter guard, rotate the turret so the cutting blade is facing outwards. Release the blade clamping screw.
Push the black pin away from you as far as it will go.
- 2a. Change or turn over the blade and replace it between the two clamping plates, push the blade in as far as it will go.
Set the Clamp plates in position. Whilst holding the blade in position, tighten the blade clamping screw and rotate the turret back to the cutting position. Replace the guard ensuring it is locked closed.

Using the Scoring blade

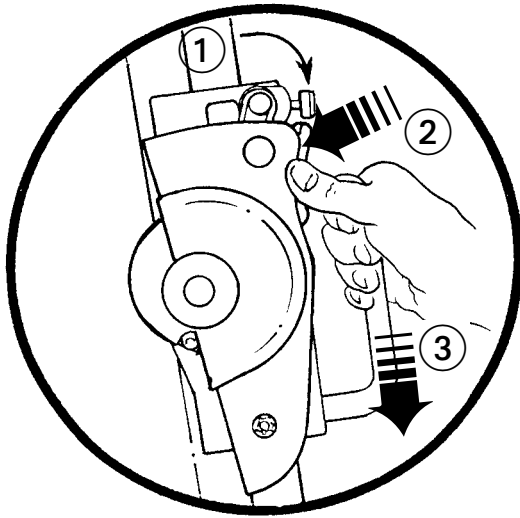

Changing the Scoring blade

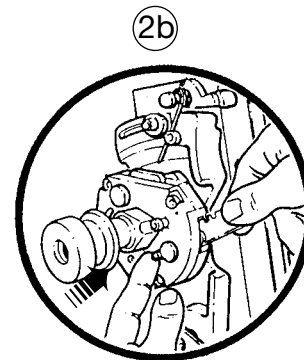
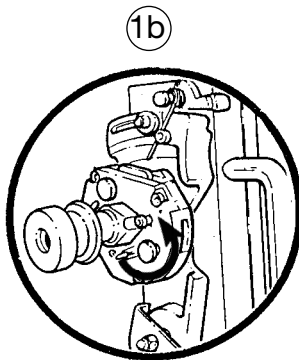

The scoring blade is designed to score acrylics, plexiglass and other similar rigid plastics. Trials should be carried out on scrap materials first to ensure you obtain the required standard of cut.

Scoring/Breaking Technique

Select the Scoring Blade position on the turret and clamp the material in the machine.

1. Turn the Ratchet Hold-off Knob to disengage the ratchet.
2. Clamp the plastic to be scored in the machine, position and depress the cutting head so that the blade touches the plastic at the top.
3. Apply thumb pressure to the cutter and draw the blade down the material in one continuous motion.

Remove the plastic from the machine and snap it by hand.

CAUTION: ALWAYS USE HAND AND EYE PROTECTION WHEN SNAPPING PLASTIC

Changing the Scoring blade

Unlock and swing down the cutter guard, rotate the turret so the scoring blade is facing outwards.

- 1b. Release the blade clamping screw.
- 2b. Eject the blade using the black ejector pin, replace the blade to the right of the clamping plate, push the blade in as far as it will go and tighten the blade clamping screw.

Rotate the turret back to the cutting position. Replace the guard ensuring it is locked closed.

Replacement blades are available from Keencut or your distributor.

Using and changing the Glass cutter

ALWAYS WEAR EYE PROTECTION WHEN CUTTING GLASS

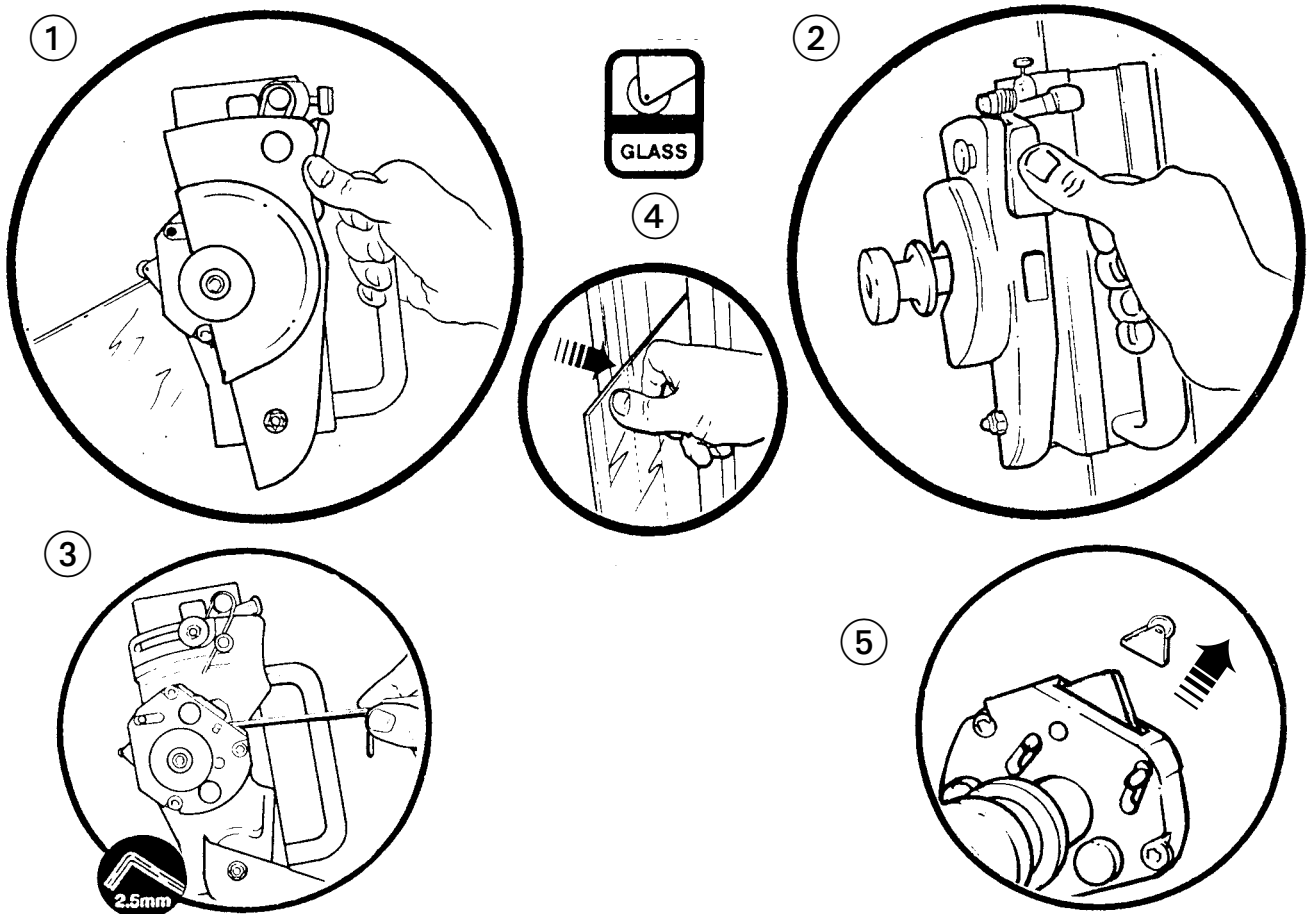

Select the Glass cutter position on the turret, place the glass on the machine loading from the right hand side.

1. Apply the clamp lightly and raise the cutting head beyond the top of the glass.
2. Press to engage the cutter fully. The cutting head will automatically adjust itself for the thickness of the glass.
Gently draw the cutter onto the glass and down to the bottom of the machine in one gentle smooth and continuous motion where it will disengage automatically.

Check the score line, it should be very faint and continuous.

- If the score is too deep the line will appear white and small slithers of glass may be seen falling from it. the scoring pressure needs reducing.
 - The score is too light when the glass cutting wheel 'skips' and does not produce a continuous line. the scoring pressure needs increasing.
3. Should the score pressure require increasing or decreasing the scoring pressure adjustment screw can be adjusted by turning clockwise or counter-clockwise accordingly.
 4. To break the glass, apply firm pressure to the left hand side of the score line adjacent to the top edge of the glass.

NB: On large sheets of glass the break may only go part way down the score line, press again near the end of the break to continue it.

Never score the same line twice.

We recommend the use of nibbling pliers for the removal of amounts less than 5mm (1")

Changing the glass cutter

Unlock and swing down the cutter guard, rotate the turret so the glass cutter is facing outwards.

5. Pull out the wheel and clip assembly from the holder.

Using the Twin Wheel cutter – 5000

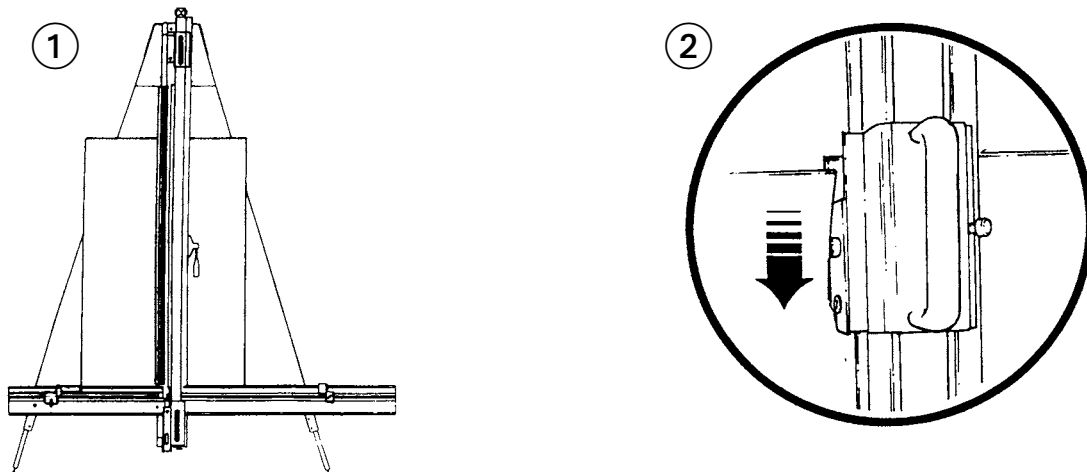

Changing the Twin Wheel cutter

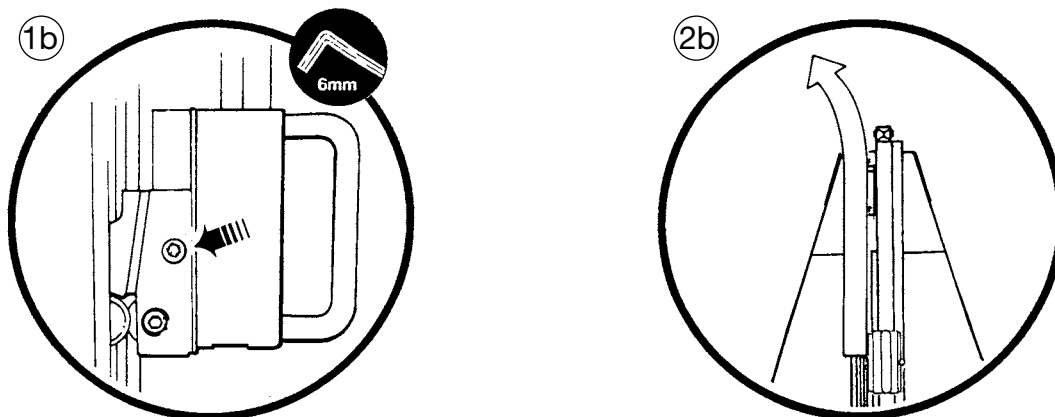

The twin wheel cutter is mounted on the upper cutting head and is used for cutting rigid materials such as medium density fibreboard (MDF, also known as SBS) and standard hardboard up to 3mm ($\frac{1}{8}$ ") or harder materials like high density fibreboard (HDF) up to 2mm ($\frac{1}{16}$ "). Many other softer boards and card can also be cut, trials should be carried out to ensure the desired quality of cut is obtained.

NOTE: The twin wheel cutter must be parked above the top level of the clamp when not in use otherwise the cutter will interfere with the sight line strip if the clamp is operated.

1. Position the material in the machine and apply the clamp.
2. Bring the twin wheel cutter down until it makes contact with the sheet edge and stop. Take a firm grip and then push the cutter down through the material without stopping.

The cutting wheels generally last more than a year for average use but this is dependant upon daily use and the materials being cut. The signs of the wheels wearing out are:

- A rough finish predominately on the right hand side of the cut, with flaking on materials such as MDF.
- The bottom 5mm ($\frac{1}{4}$ ") of the cut bursting out rather than being cut neatly.
- The board trying to turn under the clamp when being cut (also check the clamp pressure).

Changing the twin wheel cutter

Lock the cutting head at a convenient height using the white nylon locking screw.

- 1b. Hold the twin wheel cutter and its guard to prevent them from falling and remove the screw with a 6mm hexagon wrench.
- 2b. Slide the cutter towards the top of the main body and lift out.

Replacement wheels or cutters are available from Keencut or your distributor.

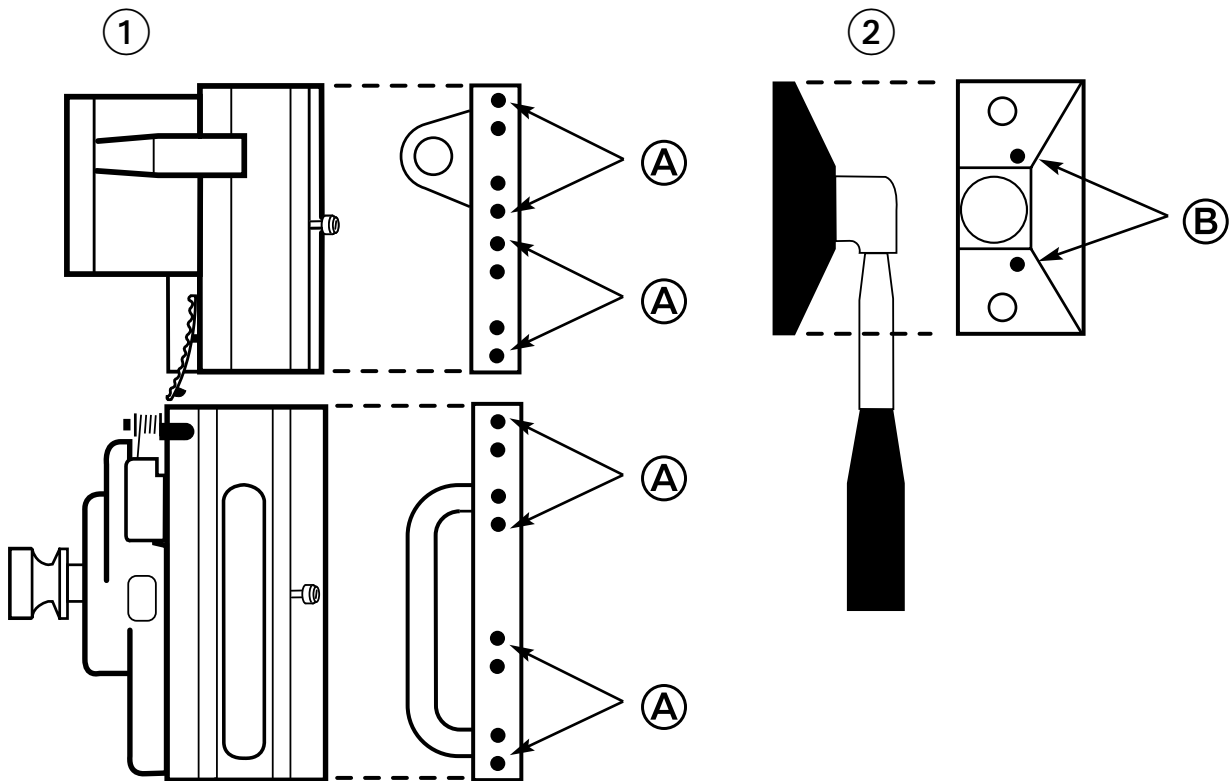

Cleaning

Keencut machines are designed to be virtually maintenance free, however we do recommend regular cleaning. Do not wipe the squaring arm channels or remove any debris with fingers, as it may contain sharp particles such as glass. Use a vacuum cleaner if possible or if a soft brush is used, work slowly and do not allow particles to flick off of the bristles.

Lubrication

The slideway can be cleaned and lubricated occasionally using a silicone lubricant. Removing any excess with a cloth.

The multi-cutter assembly may require dusting out periodically do not lubricate or adjust without seeking further advice from your distributor or Keencut.

DO NOT USE OIL ON ANY PART OF THE MACHINE

Except glass cutting oil on the glass cutting wheel only

Adjusting the sliding bearings

1. Attach the balance weight (if fitted, see page 6.2) to the other cutting head, hold the cutter at waist height and place a 2mm Hexagon wrench on the top adjustment screw. Move the cutting head up and down and tighten the screw very gradually until the cutting head does not fall under its own weight. Loosen the screw by the smallest amount you can until it does fall under its own weight. repeat the process with the other three adjustment screws Ⓐ.

Adjusting the Clamp pressure

2. The pressure of the clamp is in relation to the amount of pressure applied to the operating handle. However in time the *maximum* clamping pressure can reduce due to wear on the friction block (hidden within the machine), compensation for this can be made by adjusting the two small grub screws Ⓑ in the operating handle housing as shown. Turning the screws clockwise will increase the maximum clamping pressure.